

Cedar Picnic Table Assembly Manual

Thank you for purchasing a Cedar Picnic Table. Please take the time to identify all the parts prior to assembly.

Please use Safety Eye wear and Gloves while Assembling. Be sure to read and follow all operating instructions for any tools used during assembly. Remember- NO SAW CUTTING IS REQUIRED!

Safety Points and Other Considerations

Our products are built for use based on proper installation and normal residential use, on level ground.

Please follow the instruction manual when assembling your Cedar Picnic Table and retain the manual for future maintenance purposes.

Some of the safety and usage measures you may wish to consider include:

-If the product is elevated, any structural and building code requirements are solely the customer's responsibility, and should be abided by.

-In high or gusty wind conditions it is advisable to keep the structure securely grounded.

-Have a regular maintenance plan to ensure all components are screwed together tight.



6x5 Cedar Picnic Table Dimensions:

- A: Table Height = 30 3/4"
- B: Table Width = 34 1/4"
- C: Table Length = 66"
- D: Bench Height = 17 1/2"
- E: Bench Width = 11 1/4"
- F: Bench Length = 66"
- G: Overall Width = 64 3/4"

**Estimated Assembly Time for the
Cedar Picnic Table = 2 Hours**

In the event of a missing or broken piece, simply call the Outdoor Living Today Customer Support Line @ 1-888-658-1658 within 30 days of the delivery of your purchase. It is our commitment to you to courier replacement parts, free of charge, within 10 business days of this notification. Replacement parts will not be provided free of charge after the 30 day grace period.

Exploded View and Parts List for Cedar Picnic Table

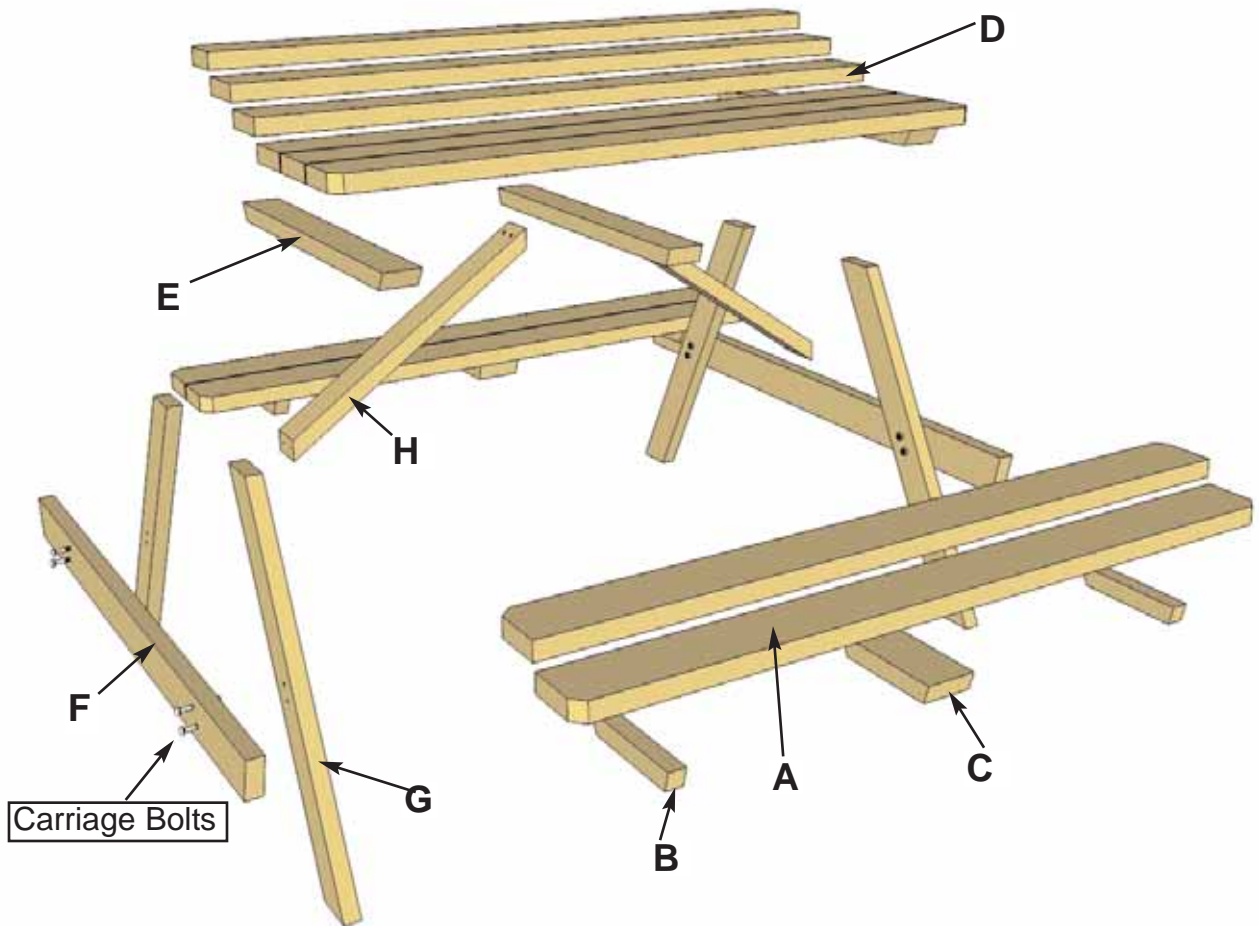

Important: When unpacking your Picnic Table from the shipping box, be sure to inventory all parts. If you discover missing or damaged pieces, please call our Toll Free Customer Support Line @ 1-888-658-1658 for fast and courteous Customer Service.

Note: Use Cardboard from the Shipping Box to lay on the ground while assembling your Picnic Table to avoid scratching wood surfaces.

Thank you for purchasing one of our Cedar Picnic Tables. Please take the time to identify all the parts prior to assembly.

Parts Lists:	T	W	L	Qty.
A - Bench /Outside Table Top Boards (Angled Corners on one side)	1 1/2"	5 1/2"	66"	6
B - Bench Cleats - End	1 1/2"	1 1/2"	10"	4
C - Bench Cleats- Middle	1 1/2"	3 1/2"	10"	2
D - Table Top Boards	1 1/2"	5 1/2"	66"	4
E - Table Top Cleats	1 1/2"	3 1/2"	33 1/2"	3
F - Bench Supports	1 1/2"	3 1/2"	62 1/2"	2
G - Legs	1 1/2"	3 1/2"	33 3/4"	4
H - Angle Brackets	1 1/2"	3 1/2"	28"	2
I - Spacer Blocks (not shown)	1/4"	2"	2"	10

Specifications:
 Wood Species - Western Red Cedar
 Grade - Architectural Knotty or Better
 Carriage Bolts & Washers - Zinc Plated
 2 1/2" Screws - Yellow Zinc

CEDAR PICNIC TABLE HARDWARE PACKAGE

Hardware Kit (Provided)

Note: screws and nails shown actual size.

2 1/2"



Square
Drive Bit



Carriage Bolt / Nut
and Washer
(8 each)



Tools Required (Not Provided)



Screw Gun/Drill



Tape Measure



Wood Clamp



9/16" Wrench



Pliers



Level



1/8" Drill Bit

Safety Equipment Required (Not Provided)



Safety Glasses



Work Gloves

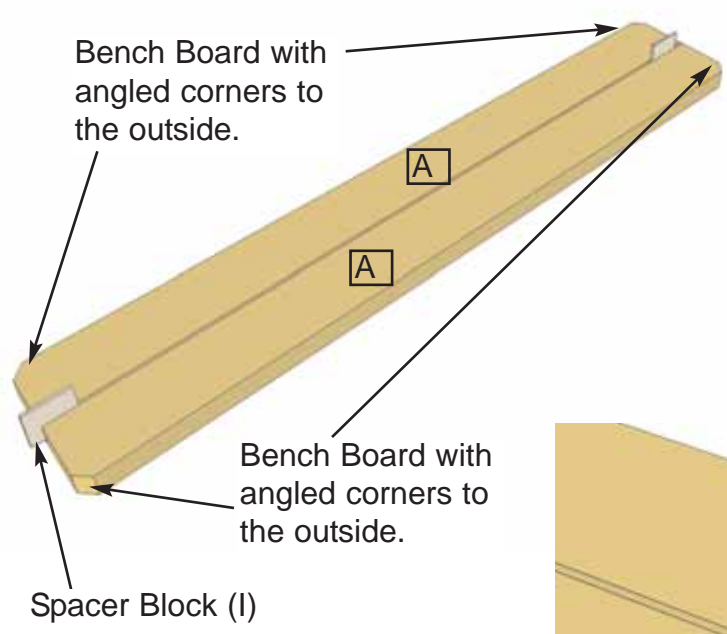

1. Start by inspecting all Bench /Outside Table Top Boards (A). There are 6 pieces with angle cut corners on 1 side. Select pieces that will be best suitable for seating and for your table top. Lay 2 pieces down on a flat smooth surface. We suggest laying the cardboard packaging underneath to prevent unnecessary scratching of the wood surface. Place best face to the ground as Picnic Table will be flipped over when assembly is complete. Locate Space Blocks (I) and slide between both Bench Board Pieces.

Important: Choose Bench/ Outside Table Top Boards for Quality and Color. Place Best Face Down as Picnic Table will be flipped over when Assembly is complete.

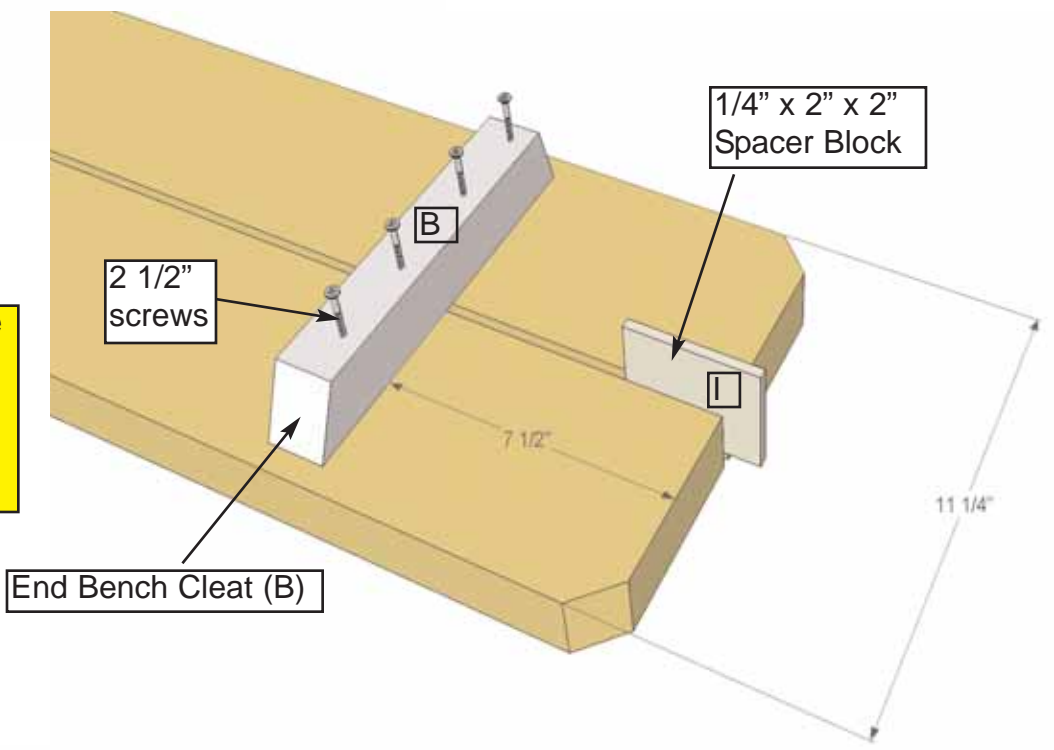

2. Measure 11 1/4" wide with Bench Boards and Space Blocks tight together. Attach End Bench Cleat (B) 7 1/2" from the end with 4 - 2 1/2" screws. Center Clear from side to side. Do not fasten screws completely until **Step 3.**

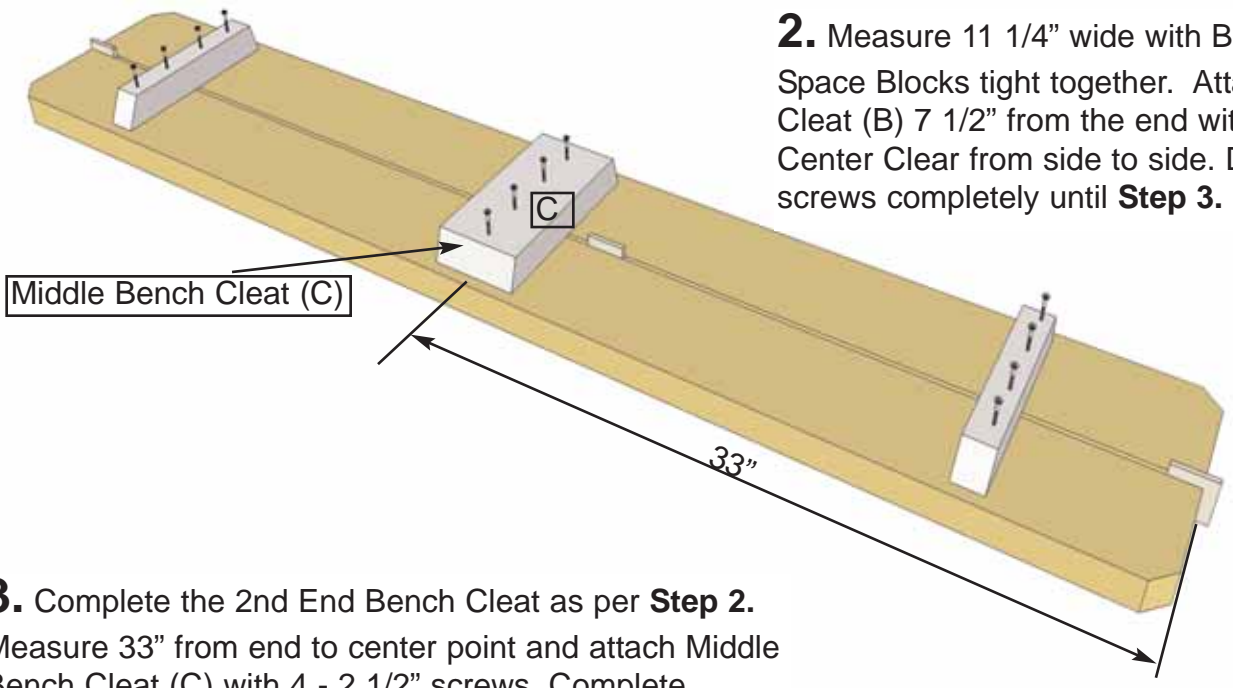

3. Complete the 2nd End Bench Cleat as per **Step 2.** Measure 33" from end to center point and attach Middle Bench Cleat (C) with 4 - 2 1/2" screws. Complete attachment of all cleat screws. Complete 2nd Bench as previously described before moving forward.

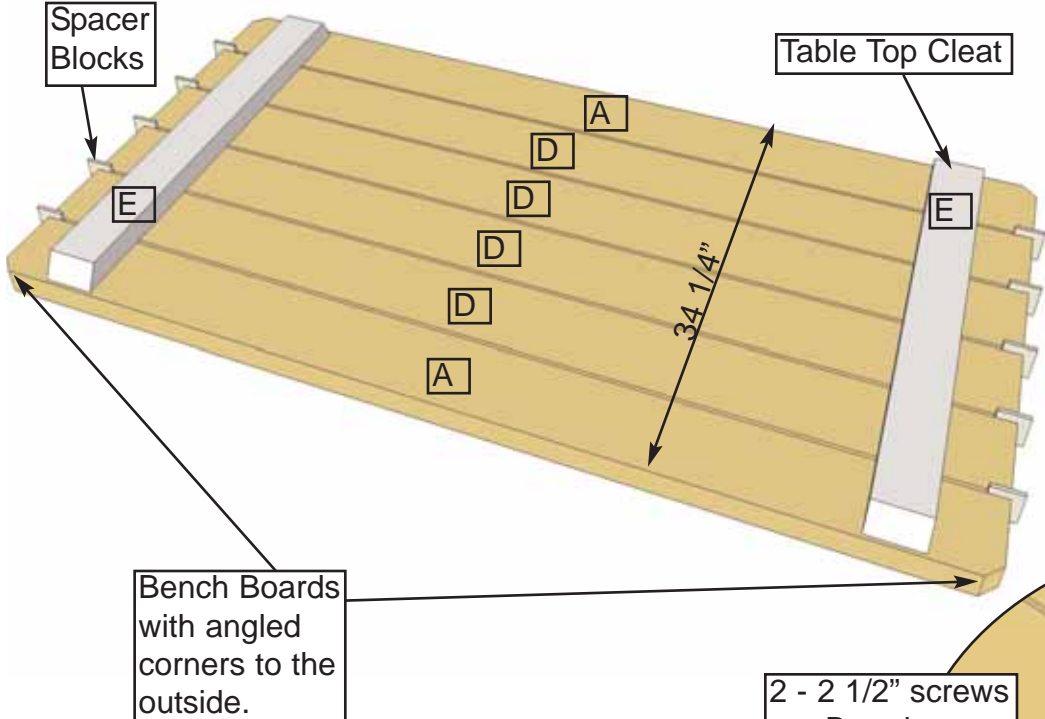

4. Lay out 2 Outside Table Top Boards (A) and 4 Table Top Boards (D) as illustrated to the left. Use 1/4" thick Spacer Blocks to evenly space boards so the total **Table Top Width = 34 1/4"**.

Position 2 Table Top Cleats (E) 4" from the ends and secure to Table Top with 2 - 2 1/2" per board. (12 screws per cleat).

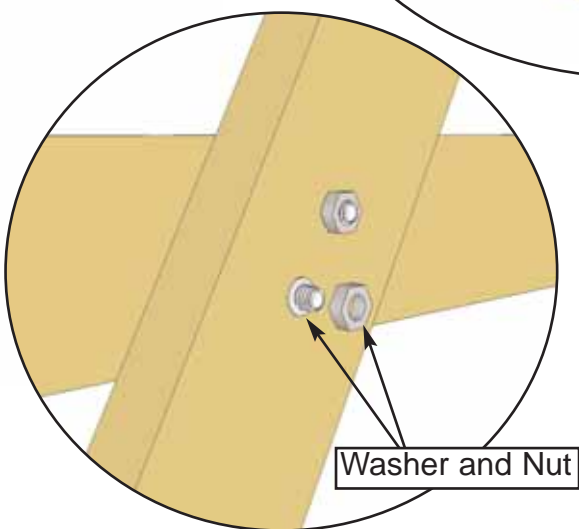
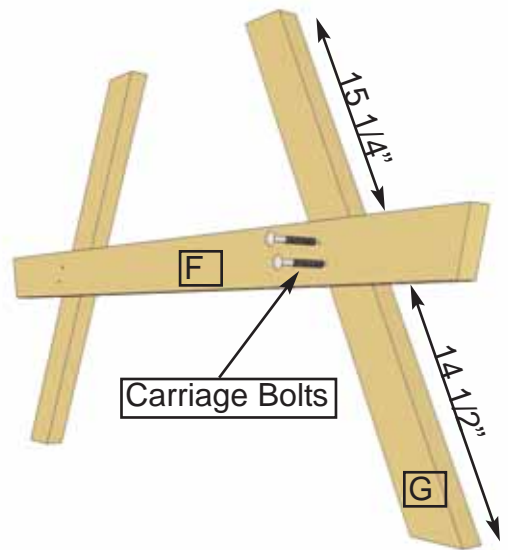
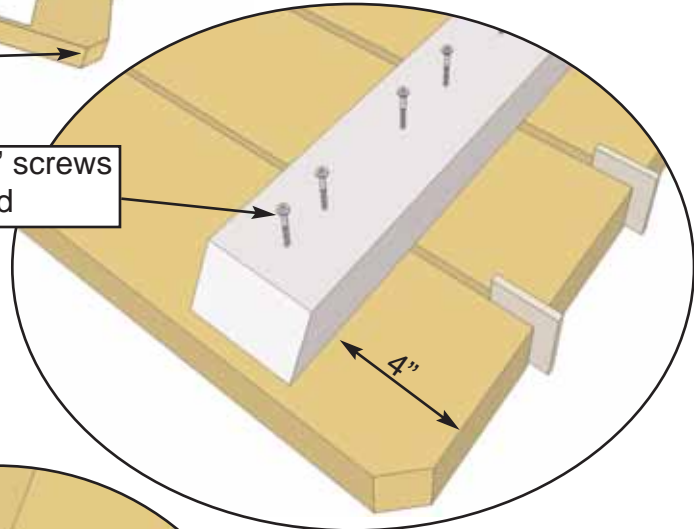

5. Locate Bench Support (F) and 2 Legs (G). Slide Carriage Bolts through Pre-drilled holes in each piece. Be sure to align Legs correctly with holes situated on the lower end of the Leg. Slip Washer on and tighten Nut with 9/16" Wrench to complete. Complete 2 sets of Bench Support / Leg Assembly's.

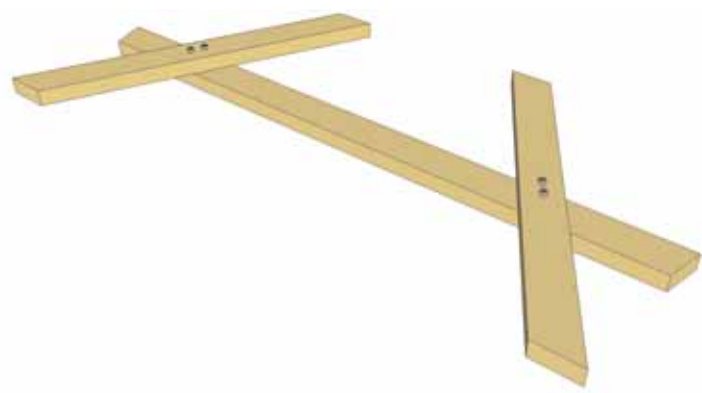

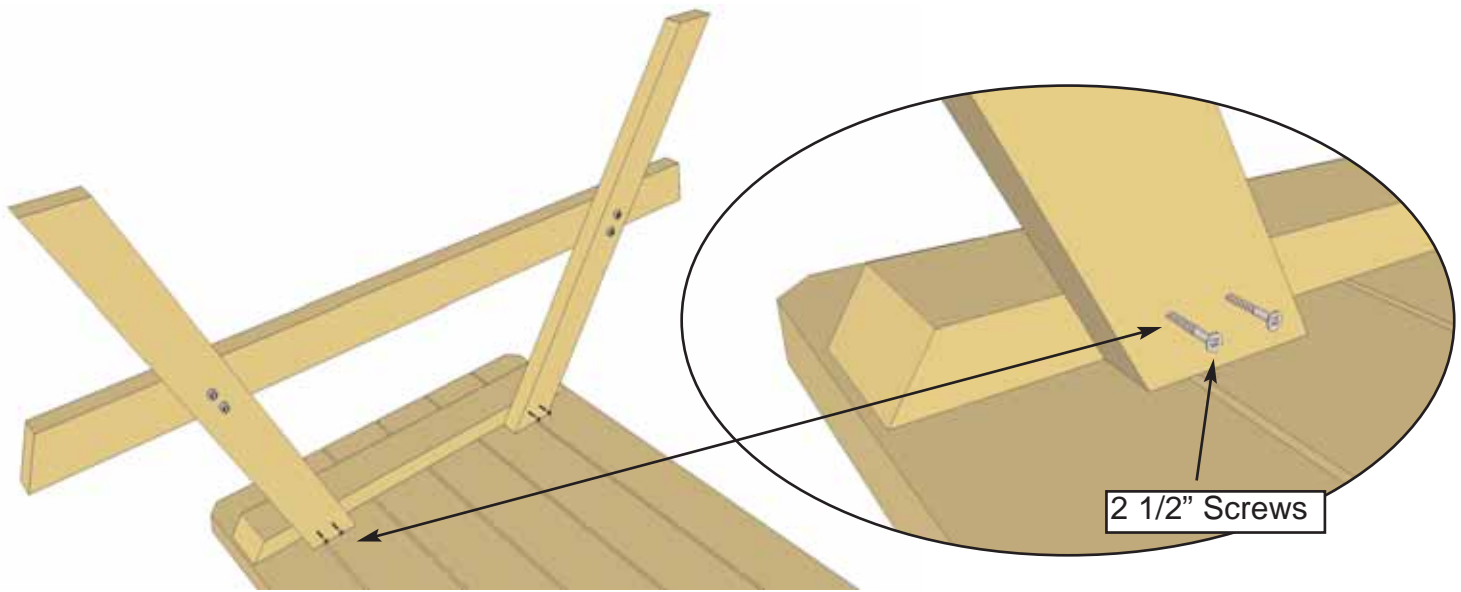

6. Evenly position Leg Ends tight against Table Top Boards and Table Top Cleat. When in correct position, pilot hole 2 holes with 1/8" drill bit and secure with 2 - 2 1/2 screws per Leg. Complete both Bench Support / Leg Assembly's.

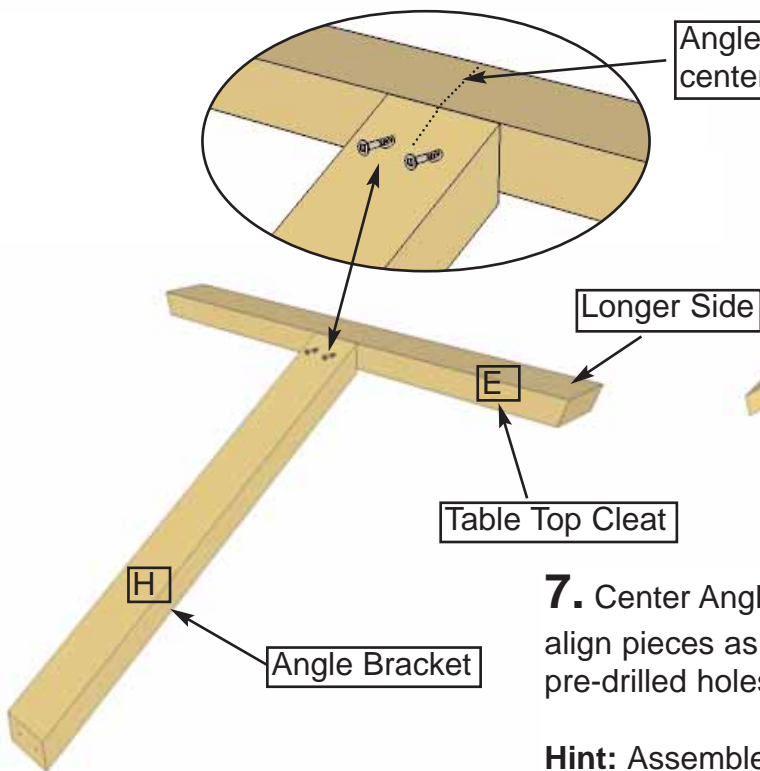
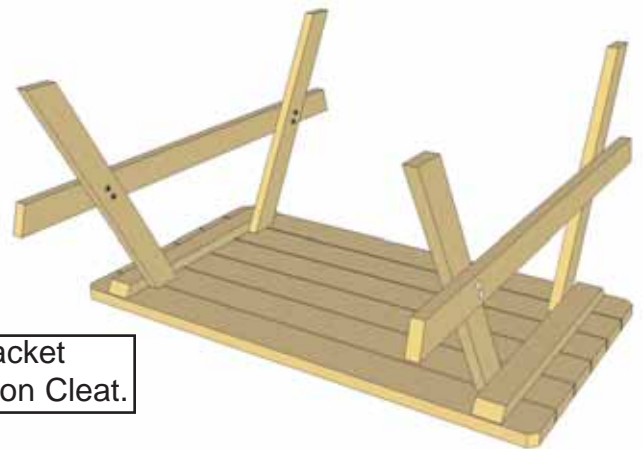
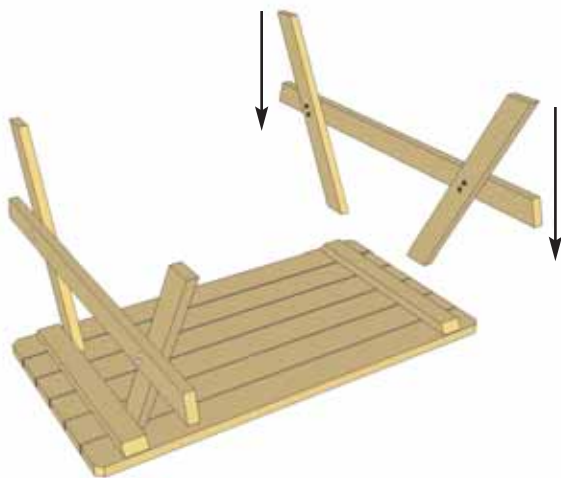

7. Center Angle Bracket (H) on Table Top Cleat (E). Be sure to align pieces as shown above. Attach with 2 - 2 1/2" screws into pre-drilled holes of Angle Bracket. Complete opposite side.

Hint: Assemble on edge of work table makes this Step easier.

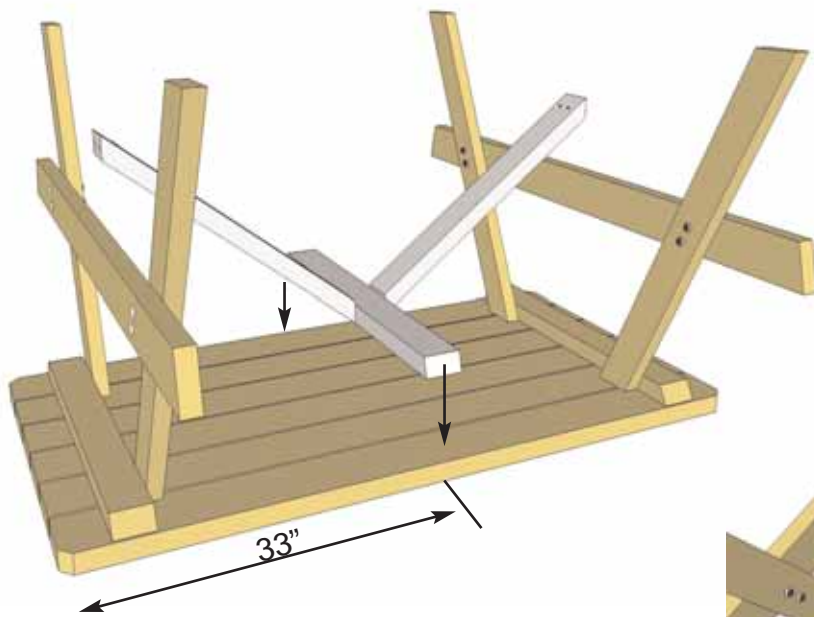

8. Flip Cleat / Angle Bracket Assembly over and center on Table Top Boards. The ends of Angle Brackets will sit flush against Bench Supports (F). Secure Cleat to Table Top Boards with 2 - 2 1/2" screws per Board. (12 in total)

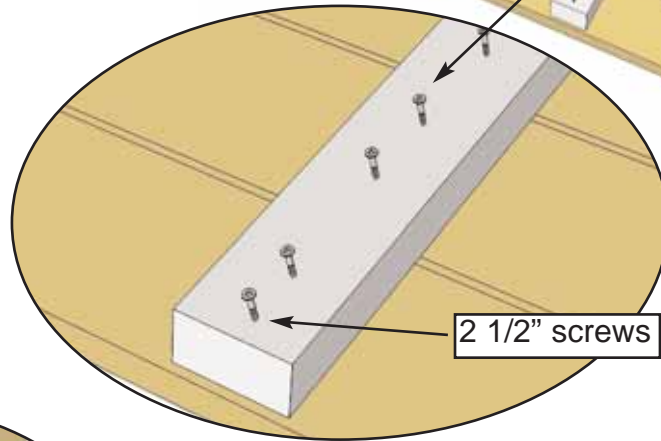
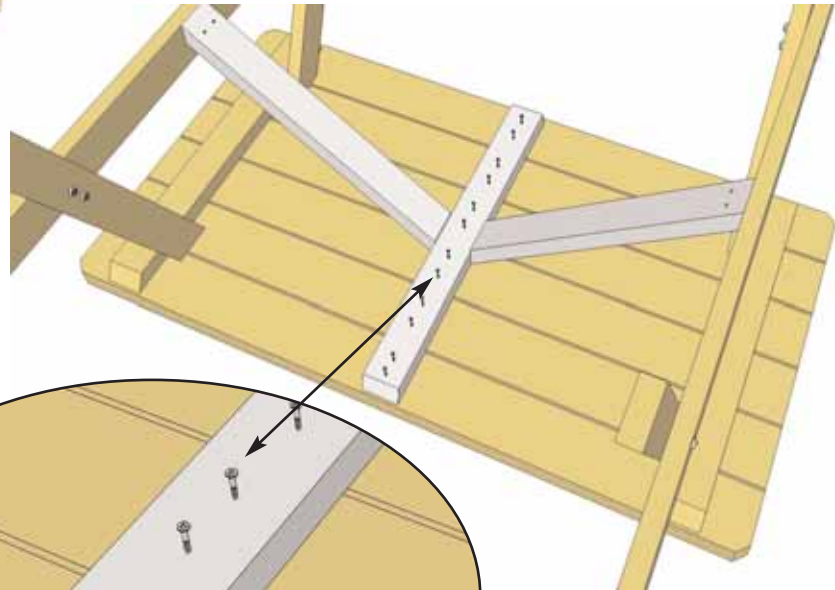

Align approximately with edge of Bench Support.

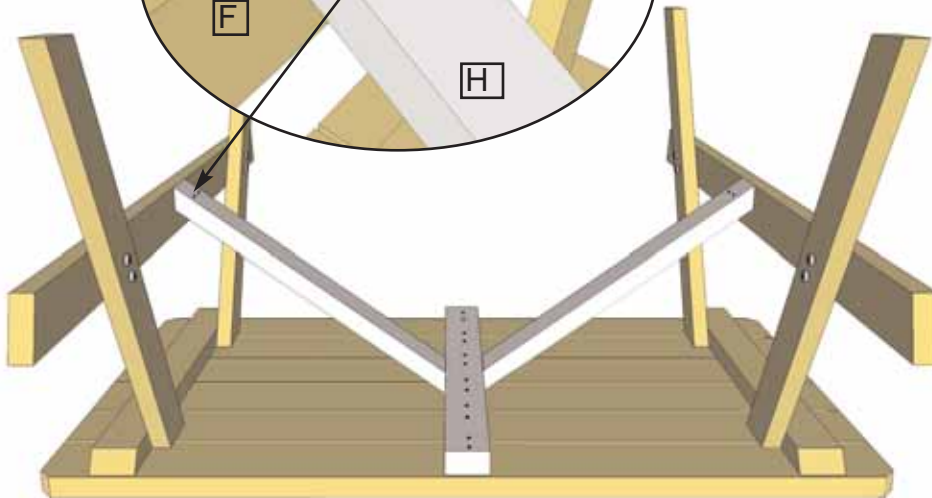
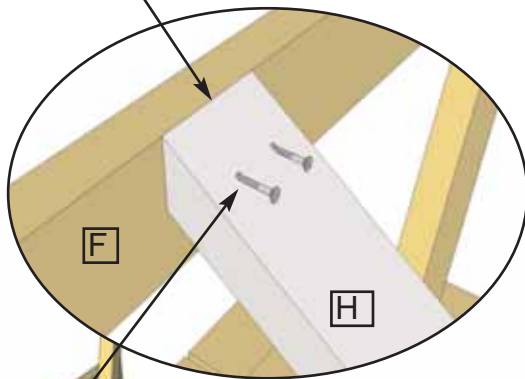

9. Prior to attaching Angle Brackets (H) to Bench Supports (F), make sure Legs are aligned straight. Secure each Angle Bracket with 2 - 2 1/2" screws into pre-drilled holes located at the end of each piece. Do not secure completely as some adjustment may be required when attaching Benches in **Step 11.**



10. Carefully flip Table over onto Legs.

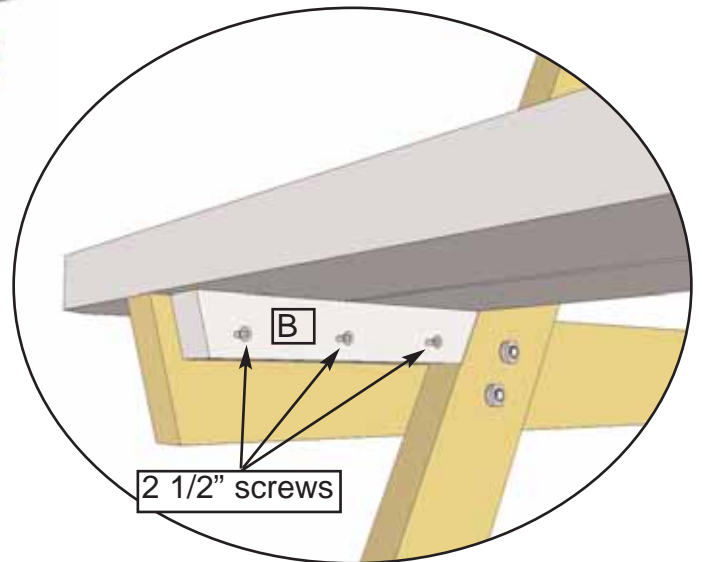
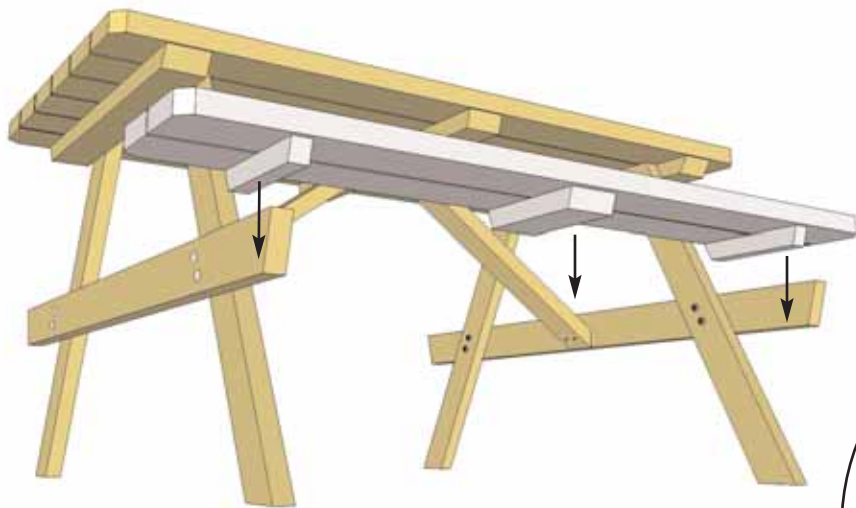

11. Lift and position pre-built Benches from **Step 3** onto Bench Supports as shown above. Screw End Bench Cleats into Bench Supports with 3 - 2 1/2" screws. Drill 1/8" pilot holes first to prevent wood from splitting.

Important: If the Bench Seats End Cleat is too wide to fit between Bench Supports, loosen screws from Angle Brackets in **Step 9** and re-adjust Legs. Be sure to tighten Angle Bracket screws when complete. Complete both Bench attachments.

Congratulations on assembling your Cedar Picnic Table

Note; The Cedar Picnic Table is shipped as an unfinished product. If exposed to the elements, the western red cedar lumber will weather to a silvery-gray color. If you plan on treating the wood, we recommend that you consult with a paint and stain dealer in your area for their recommendations.



We hope your experience assembling your Cedar Picnic Table has been both positive and rewarding.

We value your feedback and would like to hear back from you on how well we are doing in the following areas:

1. **Customer Service**
2. **On Time Shipping**
3. **Motor Freight Delivery**
4. **Quality of Materials**
5. **Assembly Manual**
6. **Overall Satisfaction.**

Please call, write or email us at:

Outdoor Living Today

Canadian Address
9393 287th Street
Maple Ridge, British Columbia
Canada V2W 1L1

United States Address
P.O. Box 96
Sumas, Washington
USA 98295



The materials contained in this Assembly Manual may be downloaded or copied provided that ALL copies retain the copyright and any other proprietary notices contained on the materials. No material may be modified, edited or taken out of context such that its use creates a false or misleading statement or impression as to the positions, statements or actions.